

Electrical circuits







Electricity is a flow of **charges**. Electricity can flow through **conductors** but not through **insulators**. Metals are good conductors of electricity. Plastics are good insulators.

For current to flow in a circuit, you need:

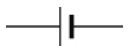
- a complete circuit with no gaps
- a cell or power supply.

We can use **models** to help us to think about electricity and circuits. One model for a circuit is a central heating system. The boiler and pump represent the cell, the pipes represent the wires, and the radiators represent bulbs.

Symbols

Component	Symbol	Component	Symbol	Component	Symbol
cell		bulb		ammeter	
switch		resistor		voltmeter	

Measuring electricity

- **Current** is the amount of electricity flowing in the circuit.
- It is measured using an **ammeter** connected in series.
- The units for current are **amps (A)**.
- **Voltage** provides the 'push' and energy.
- It is measured using a **voltmeter** connected in parallel.
- The units are **volts (V)**.

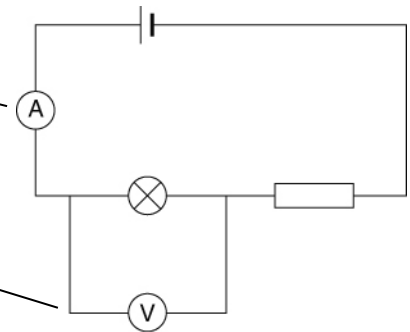

Resistance

The **resistance** of a circuit is a way of saying how easy or difficult it is for electricity to flow.

- High resistance = hard for electricity to flow = small current.
- Low resistance = easy for electricity to flow = large current.

Thin wires and resistors have high resistances. Thick wires have low resistances.

Series and parallel circuits

Circuits can be **series** or **parallel** circuits.

Series circuit

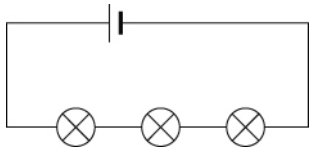

If one bulb breaks, all the others go off.
The current is the same everywhere.
If you put more bulbs in they will be dimmer, because it is harder for the electricity to get through. The resistance of the circuit is higher with more bulbs.

Parallel circuit

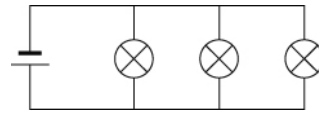

If one bulb breaks, the bulbs in the other branches stay on.
The current splits up when it comes to a branch. The current in all the branches adds up to the current in the main part of a circuit.
If you add more bulbs, they stay bright. It is easier for the current to flow with more branches, because there are more ways for the charges to go.

Safety

Electricity can be dangerous if it is not used properly. It can cause:

- fires
- burns
- shocks that can stop your heart or lungs working.

The wiring in houses is designed to be safe.

- **Fuses** are used in plugs. They melt if the current gets too high. A fuse has a **rating** that shows what current it can carry without melting. It is important to use the correct fuse.
- **Circuit breakers** also cut off the current if it gets too high. They protect the **ring mains** in buildings (loops of parallel circuits).
- Cables have three colour-coded inner wires. The live and neutral wires are part of the circuit. The earth wire works with the fuse for safety.

